

**Read and understand these instructions before installing luminaire.** This luminaire is intended for installation in accordance with the National Electrical Code and local regulations. To assure full compliance with local codes and regulations, check with your local electrical inspector before installation. To prevent electric shock, turn off electricity at main power supply before proceeding. Retain these instructions for maintenance reference.

**Vyv is not responsible for any injuries due to the improper installation or handling of its products.**

**NOTE:** Fixtures must never be lifted from sides or ends, lift fixtures only by cradling in arms until they are supported uniformly by mounting system.

## Mounting Spec

### Specifications:

#### Mounting:

Steel brackets with vertical adjustability are provided to tension-mount side flanges against ceiling opening. Holes provided for chain-mounting support to building structure. End flanges are pressure fit and are removable to permit for row-mounting. Requires only 3" clearance over fixture depth i.e. a 4" deep fixture requires only 7" cavity depth (in more shallow cavity applications, fixture may be inserted prior to installation of flange kit).

#### Construction:

Die and brake-formed, heavy-gauge steel

#### Finish

White, polyester powder painted visible surfaces

### Features:

- Available in 1x4, 2x2, and 2x4 configurations
- Adjustable for drywall, plaster and similar type ceilings up to 1 inch thick
- Universal – fits most manufacturers T-Bar luminaires

### UNIVERSAL FLANGE KIT

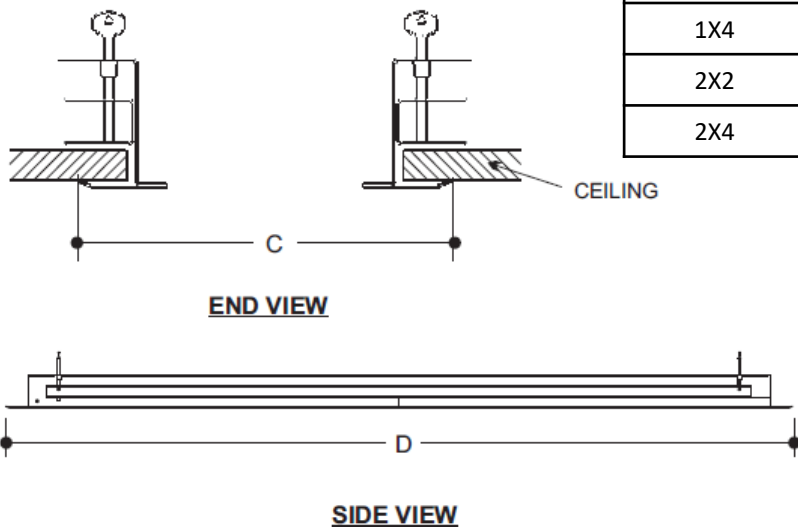

NOMINAL DIMENSIONS	CEILING OPENING		OVERALL FLANGE	
	WIDTH	LENGTH	WIDTH	LENGTH
	A	B	C	D
1X4	12 3/4"	48 1/2"	14 1/8"	49 15/16"
2X2	24 3/4"	24 1/2"	26 1/8"	25 15/16"
2X4	24 3/4"	48 1/2"	26 1/8"	49 15/16"

