

VSDLB Recessed 6” Downlight Square

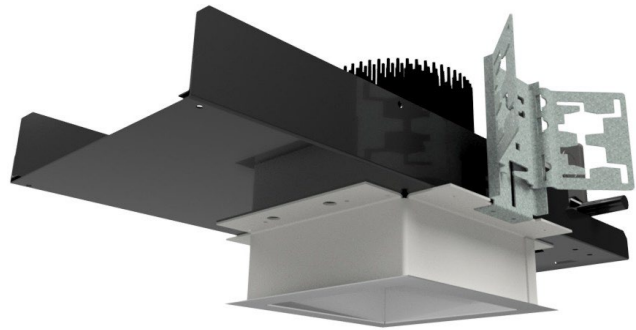

Application: The Vyv VSDLB provides sleek recessed lighting for a clean look and feel in indoor applications.

Mode Switching: Use ‘Antimicrobial+Light Mode’ when both continuous antimicrobial action and illumination are needed and ‘Enhanced Antimicrobial Mode,’ which emits a higher dosage of Vyv’s antimicrobial wavelengths, as an antimicrobial cleaning mode for when full illumination is not required. See installation instructions (INS-443) for wiring details.

Product Specifications

Lens: Solite LP1 tempered glass lens is standard.

Trim: Integrated LED module with Spun Aluminum Reflector. Square haze anodized reflector is standard.

Housing: Fabricated from stamped and die formed galvanized steel. Supplied with a junction box suitable for through wiring (4in/4out). Sliding light engine for easy service.

Electrical: LEDs coupled with high efficiency drivers provide quality illumination. Fixtures supplied with 0-10V dimming down to 1% as standard.

LED: Patented Vyv LED package. The range of CCT (correlated color temperature) follows the color uniformity guidelines of the American National Standard regarding specifications for the chromaticity of solid-state lighting (SSL) products as per ANSI C78.377-2017.

Approvals: Fixtures are cETLus listed for Damp Location. Wet location optional. EPA Est. 94839-RI-1. Covered by one or more of the following U.S. Patent Numbers: 9,333,274; 9,439,989; 9,713,223; 9,927,097; 10,357,582; 10,753,575



Ordering

Project: _____ Date: _____
 Luminaire Type: _____ Approved By: _____
 Product Code: _____

Series	Lumens	Features	CCT	Reflector Finish	Lens	Voltage	Options
VSDLB					LP1		
	02 2,000lm	N Dual Mode (Antimicrobial+Light Mode & Enhanced Antimicrobial Mode)	30 3000K	FP1 Haze (Anodized) Standard	LP1	120 120V	Driver
	03 3,000lm		35 3500K			277 277V	
			40 4000K	FP2 White Powder Coat	Approval		
		W Antimicrobial +Light Mode		FP3 Black Powder Coat			WL Wet Location
				FP4 Custom Color (Consult Factory)			CRI*
							90CRI 90 CRI

* 90+CRI reduces lumen output by 20%.

Dimensions

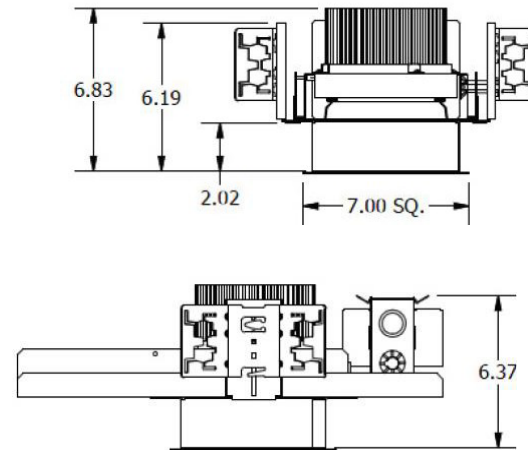
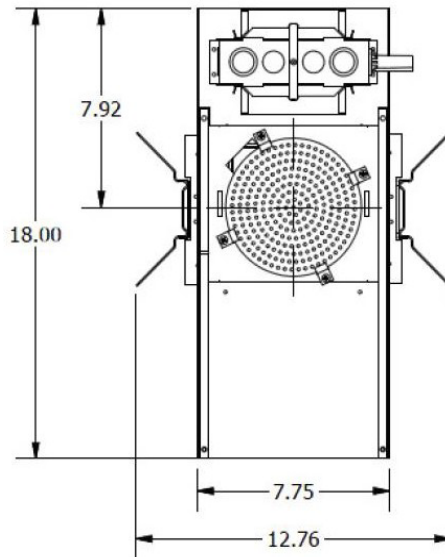

Electrical

Input Frequency	50/60Hz
Power Factor	>.9
Control	On/Off via standard light switch Antimicrobial+Light Mode to Enhanced Antimicrobial Mode (optional) via low voltage switch or controls.

Some options may not be available in all combinations.
 All fixture configurations subject to final factory approval.
 Vyv will work with your facility to customize a design for lighting and antimicrobial action.
 Vyv, Inc. reserves the right to upgrade and improve products without notice.

SPECIFICATIONS AND DATA SUBJECT TO CHANGE WITHOUT NOTICE

Updated January 24, 2024